

INSTALLATION INSTRUCTIONS FOR CYCLOCROSS CANTILEVER BRAKE

Front wheel

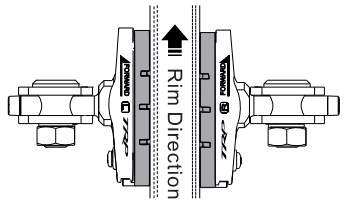

Rear wheel

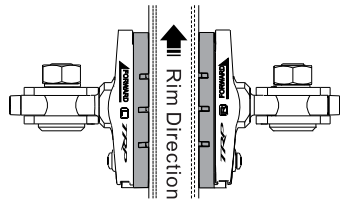

IMPORTANT:

These brakes offer considerable braking power and require practice at slow speeds before normal use.

If you are unsure about any part of the installation and set up of these brakes, consult a qualified mechanic or your local bike shop.

TRP is not liable for damage or injury as a result of improper installation or use.

A - Installation of the brake

Apply a light coating of grease to the frame and fork pivot bosses. Slide spring and brake arm onto each pivot mounting the short end of the spring into the hole at base of pivot boss and long end of spring into the slot into the brake arm. Thread supplied mounting bolt onto pivot boss. Tighten to torque of 6-8Nm.

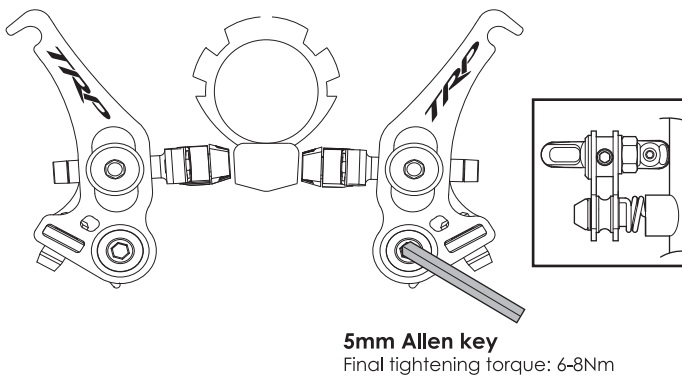

B - Brake shoe setting position

Rotate each brake arm toward the rim until brake pad contacts the rim. Align each brake pad so inside edge of pad is parallel to the braking surface of the rim. Make sure there is a 1mm gap between the top edge of the rim and the top of the pad. Holding each arm so the pad is against the rim, use a 5mm Allen key to hold the pad fixing bolt while tightening the fixing nut using a 13mm spanner. Tighten to a final torque of 7-9 Nm.

To set the brake pad Toe-in, loosen the bolt in the end of the pad holder post using a 4mm Allen wrench. Rotate the brake arm towards the rim and align the brake pad toe in to the desired angle then retighten the bolt to a final torque of 5-7 Nm.

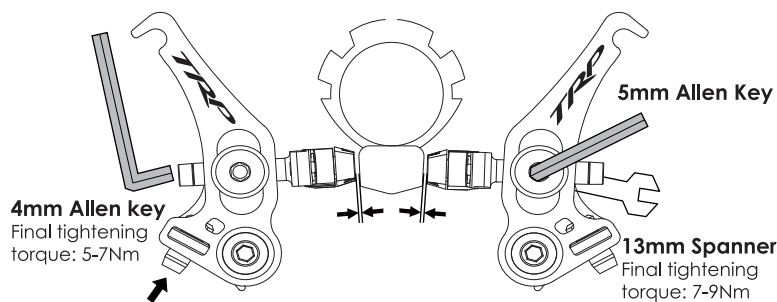

NOTE: Balance the pad clearance by fine-tuning spring tension adjuster. Max. torque is 4Nm

D - Connecting the brake cable

Thread the brake cable through the center bolt of the straddle cable carrier making sure that there is a minimum of 20mm between the end of the cable housing stop and the top of the straddle cable carrier. Hold the straddle cable carrier center bolt with a 5mm allen wrench and tighten the nut using a 10mm spanner.

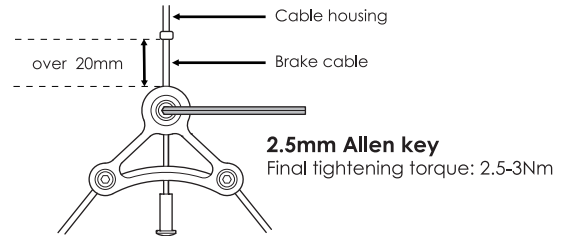

E - Connecting the straddle cable

Thread the straddle cable through the barrel adjuster cable stop and make sure the cable head is seated inside the barrel adjuster end. Fit the barrel adjuster end into the brake arm slots and then pull the cable through the straddle cable carrier and into the cable fixing end. Holding the brake arms together so that the pads are contacting the rim, fit the cable fixing end into the other brake arm slots and pull the straddle cable through until it is tight. Using two 2.5mm allen wrenches, one to hold the anchor bolt from the backside and one on the other side, tighten the anchor bolts to a torque of 2.5-3Nm.

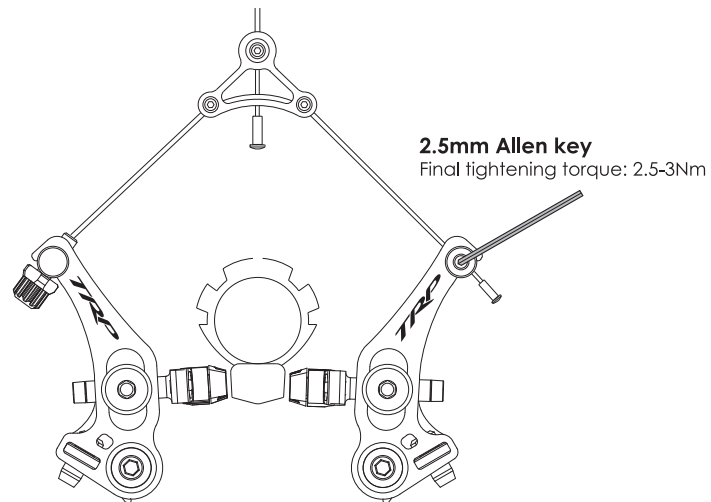

F - Centering the brake

Squeeze the brake lever a few times while checking to see that the return spring tension is equal on both arms. Pad/rim contact and return should occur equally on each side. If you need to adjust the spring balance, you can use the spring tension adjuster screws to increase or decrease spring tension until you have balanced contact and return. Once you have the tension balanced, tighten the 2.5mm allen bolts on the straddle cable carrier to secure it in position on the straddle cable. Tighten these bolts to 1-1.5Nm

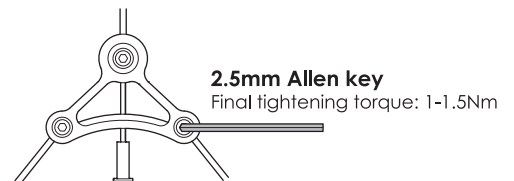

QUESTIONS?

For questions about setup, usage or general inquiries, please e-mail or call toll free at:

TRP Brakes
info@trpbrakes.com
1-877-807-4162
www.trpbrakes.com